



**Western Regional Air Partnership
Work Plan Update
(2005-07)**

May 5, 2005

Table of Contents

I.	Introduction	1
II.	Project Summaries	7
	Initiatives Oversight Committee	7
	Stationary Sources Joint Forum	7
	Fire Emissions Joint Forum	8
	Dust Emissions Joint Forum	12
	Mobile Source Forum	14
	Sources In and Near Class I Areas Forum	14
	Economic Analysis Forum	15
	Air Quality Modeling Forum	17
	Emissions Forum	22
	Tribal Data Development Work Group	26
	Ambient Monitoring and Reporting Forum	28
	Technical Oversight Committee	29
	Attribution of Haze Work Group	30
	309 Coordinating Committee	31
	Air Managers Committee	31
	Communications Committee	35
	Figure 1. Strategic Plan Timeline (Updated October 13, 2004)	4
	Figure 2. Summary of 2018 Regional Haze Control Strategy Evaluations (March 2005)	6

I. INTRODUCTION

This work plan summarizes activities and expenditures planned by the Western Regional Air Partnership (WRAP) for calendar years 2005-2007, including activities initiated in earlier years and new activities. The WRAP is funded through annual grants from the U.S. EPA. This work plan will be submitted to EPA in support of the WRAP's grant application for the federal FY05 funds awarded (\$2,936,826) to the WRAP to support ongoing technical and policy work related to the development of state and tribal regional haze plans for the West.

The most recent WRAP work plan (calendar year 2005 work plan funded with the WRAP's federal FY04 grant) was finalized on December 7, 2004. Recently, the EPA has accelerated its grant award process such that the FY05 grant is available to the WRAP and other regional haze planning organizations approximately six months sooner than in years past. Since the latest WRAP work plan is only a few months old, the WRAP is responding to the early availability of EPA funds by providing an update to the December 7, 2004 work plan. Background information about the WRAP, its management process, and stakeholder involvement are not repeated here, but can be found in the December 7, 2004 version of the work plan, available at <http://www.wrapair.org/WRAP/docs.html>.

In addition to including new and expanded tasks, this work plan update covers an expanded period of 2005 through 2007. This is a critical time period since most of the WRAP's technical and policy work must be completed by the end of 2006 so that states can incorporate the WRAP's products in their implementation plans which are due to the EPA by December 2007 (tribes are not subject to this deadline).

In developing this work plan, WRAP forums and committees were asked to consider the essential needs of state and tribal implementation plans and to ensure they could be met in this time frame and with the available resources. This work plan update assumes that the vast majority of technical and policy endeavors should be completed with the funds available as of this grant and by the end of 2006.

This work plan follows the direction set in the WRAP's long-term strategic plan, which was adopted in 2003.¹ Figure 1 shows the strategic plan time line and major project milestones. The time line and major milestones from the strategic plan provide the overall schedule and objectives for this work plan. The Strategic Plan also serves as an instrument of coordination and provides the direction and transparency needed to foster stakeholder participation and consensus-based decision making, which are key features of the WRAP process. The strategic plan also provides guidance to the individual plans of WRAP forums and committees which are included in this work plan.

¹ See <http://www.wrapair.org/forums/sp/docs.html>

On a more general level, the WRAP's planning process must accommodate a unique landscape of environmental, social, economic, and political issues. The WRAP region includes 116 (or 75 percent) of the nation's 156 mandatory federal Class I areas, half the land mass of the United States (not including Alaska), a very large portion of publicly-owned lands, and numerous tribal jurisdictions (many with large land areas). It also emits a minority of total U.S. emissions, borders both Canada and Mexico, and receives pollution from Asia.

Most WRAP members will not have to contend with ongoing ozone and particulate matter nonattainment issues, which simplifies air quality planning to some extent, but many WRAP members are faced with rapid population growth and other challenges to preventing deterioration of air quality. Moreover, the WRAP must be sensitive to other regionally-important environmental issues, such as fire and drought. This presents a unique and challenging environment for long-term planning which is best addressed through a single, well-funded and well-organized institution at the appropriate political level. The WRAP, with the appropriate EPA financial support, provides such an institution, especially given its co-management structure shared between the Western Governors' Association and the National Tribal Environmental Council.

Finally, the WRAP's long-term planning process must be prepared to deal with relevant events beyond its control, such as federal initiatives and the ramifications of legal challenges to the RHR. One way the WRAP contends with these events is to have sufficient staffing to track the issues and to foster a constructive dialogue among its members.

Table 1: Currently Pending Projects & FY05 Grant Projects

Project Title	2005	FY05 Grant	
		2006	2007
STATIONARY SOURCES			
Regional Stationary Source Strategy Development	250,000	158,000	
FIRE			
Fire Tracking System	85,000	50,000	50,000
Regional coordination of smoke management programs	50,000		
2002 Wildfire Emission Inventories Comparative Analysis.	26,500		
Smoke Mgmt Technical and Policy Workshop	25,000		
Assessment of Apportionment Methods	25,000		
Feasibility Criteria for WRAP Fire Policies	60,000		
MOBILE SOURCES			
Offroad Retrofit Program	100,000		
ECONOMIC ANALYSIS			
Development of Baseline Economic Data	55,000		
Enhancement of Cost and Benefit Unit Values	50,000		
Screening Tool	20,000		
Economic Assessment Capability	130,000		
MODELING			
2005 RMC Support	500,000	500,000	
EMISSIONS			
2005-2007 EDMS Hosting / Operation	55,000	180,000	180,000
EDMS Enhancements		128,000	
Support for Control Strategy Analysis		75,000	
TRIBAL DATA			
Emissions Data Development Support	103,000	200,000	
Continue Emissions Inventory & TEISS Technical Support	98,000		
DUST			
Enhanced Ambient Data Analysis - CoH	50,000		
Update Handbook		20,000	
Pilot Project -NM		80,000	
Addition to Fine Fraction	30,000		
AMBIENT MONITORING AND REPORTING			
Causes of Haze		225,000	100,000
ATTRIBUTION OF HAZE			
Phase 2 Technical Support Contractor	75,000		
WIGIMS Implementation	167,000		
AIR MANAGERS COMMITTEE			
Contractor Assistance	130,000		
State Caucus Coordinator	120,000	120,000	
Health and Environmental Assessment of Haze-Related Improvements	15,000		
Traditional Tribal Practices and Regional Haze	10,000		
308 Implementation Work Group - State and Tribal Support	76,000		
Workshops on Effective Collaboration	35,000		
COMMUNICATIONS COMMITTEE			
Public Outreach and Communication on WRAP Issues	55,000		
Web Site Maintenance	23,500	25,000	
Subtotal for Pending Projects	2,419,000		
Contract Subtotal		2,091,000	

Figure 1. Strategic Plan Timeline (Updated October 13, 2004).

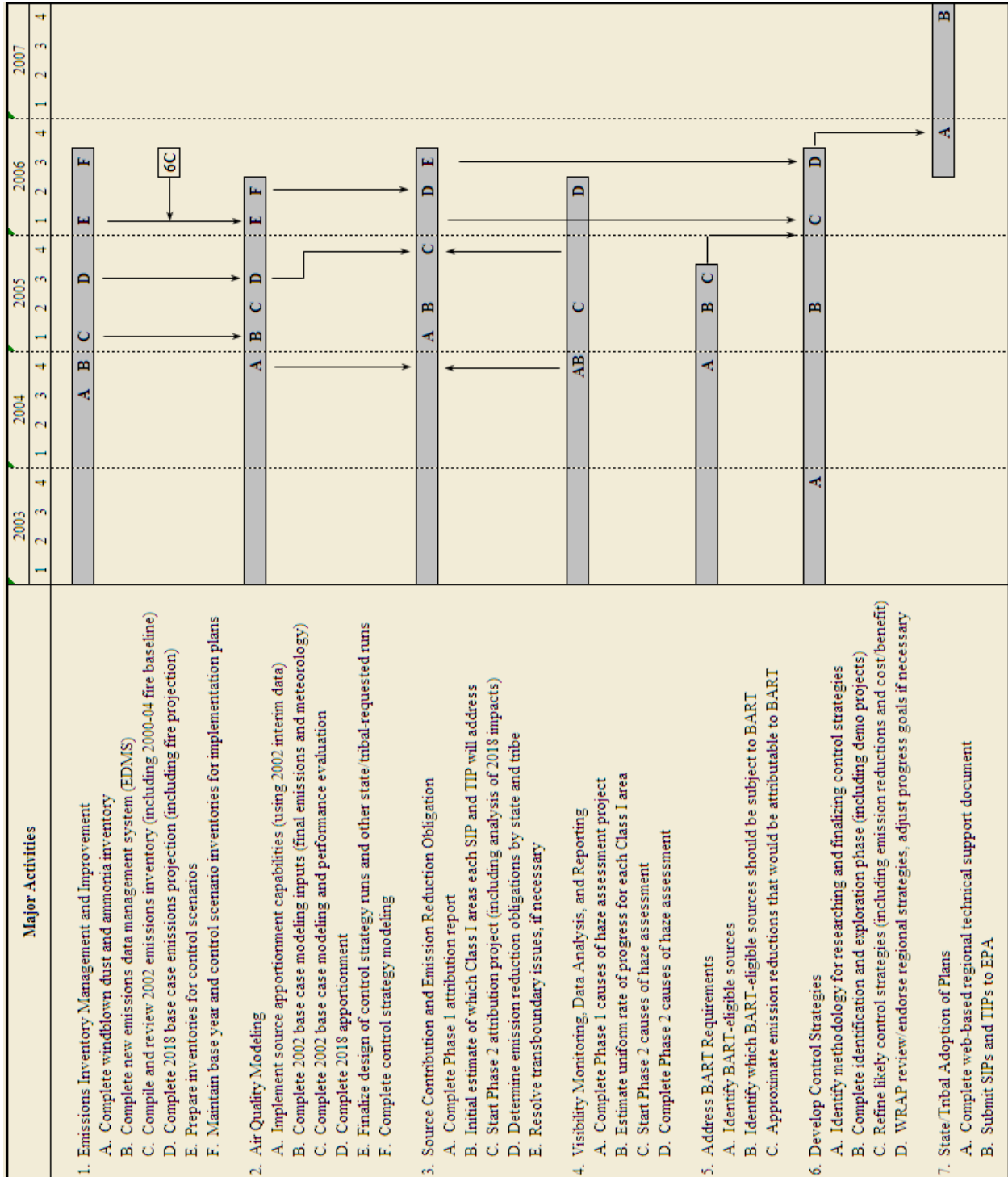

	2003				2004				2005				2006				2007			
	1	2	3	4	1	2	3	4	1	2	3	4	1	2	3	4	1	2	3	4
Tribal-Only Activities																				
8. Refine Framework for Tribal Federal Implementation on Tribal Lands																				
A. Develop policy to determine when federal implementation is appropriate																				
B. Develop guidance on what elements of a TIP may be "reasonably severable"																				
309 Activities																				
9. Emissions Tracking																				
A. SO2 emissions for comparison to milestones																				
B. Fire emissions																				
C. Clean air corridor and mobile source emissions																				
10. Renewable Energy and Energy Efficiency																				
A. Report on programs and progress																				
B. Provide technical assistance for SIPs/TIPs (continuous)																				
C. Facilitate 10/20 goals through regional credit market development (continuous)																				
11. Compliance with all 308 requirements (except SO ₂ BART) for areas outside the Colorado Plateau																				

Figure 2. Summary of 2018 Regional Haze Control Strategy Evaluations (March 2005).

<p>June through September 2005</p>	<p><u>2018 Base Case Definition</u></p> <ul style="list-style-type: none"> • Known control programs, i.e., what emissions will be in 2018 if no additional controls are adopted • Projected from 2002 emissions (2000-04 in the case of fire emissions) 	<p><u>2018 Base Case Control Programs</u></p> <ul style="list-style-type: none"> • Federal on-road and non-road mobile emissions • §309 SIPs (5-state SO₂ Annex) • Controllable fire emissions (use 2000-04 baseline for 2018) • Point and area sources: <ol style="list-style-type: none"> 1) Statutes and rules “on the books” as of 12/2004 to be implemented before 2018 2) Sources to be operational before 2018 (permitted and under construction as of 12/2004) 3) Includes quantified SIP measures, NEAPs, EACs, MACT, etc. 4) Accounts for economic and demographic factors
<p>October 2005 through March 2006</p>	<p><u>2018 Regional Control Options</u></p> <ul style="list-style-type: none"> ✚ California PM_{2.5} and ozone SIP measures ✚ BART- individual eligible sources added up for regional analysis ✚ Point Source backstop cap and trade for BART + other point sources, options for: ❖ Regional NOx ❖ Regional SO₂ ❖ Nested §309 SO₂ ❖ Others? ✚ Fire - greater application of Emissions Reduction Techniques for fire emissions to meet definition of regionally consistent enhanced smoke management programs – sensitivity evaluation ✚ Dust - greater control levels and/or spatial extent of existing Dust Control programs – sensitivity evaluation 	
<p>Not for regional analysis</p>	<ul style="list-style-type: none"> ➤ Area sources in general ➤ Dust sources in general 	

II. PROJECT SUMMARIES

Initiatives Oversight Committee

The IOC provides overall direction and review to the forums evaluating potential emissions control strategies for regional haze in the West. The IOC has identified two general areas of investigation related to how the work of the individual forums might be aggregated into regional haze plans.

IO1: Reasonable Progress Criteria

The regional haze rule requires states, when establishing reasonable progress goals, to consider the following statutory factors: the cost of compliance, the time necessary for compliance, the energy and nonair quality environmental impacts of compliance, and the remaining useful life of any potentially affected source. Furthermore, states must include a demonstration in their SIPs showing how these factors were taken into consideration in selecting each goal. The purpose of this task is to explore these factors (e.g., how they have been used or interpreted in other environmental programs) and to provide further definition and guidance with respect to using them in a regional haze SIP demonstration.

IO2: Process for Identifying Control Strategies

The WRAP strategic plan identifies a “navigational challenge” identifying and selecting emission control strategies among the large number of those potentially available. It also provides some general ideas on how to “narrow the field.” The purpose of this task is to develop a process by which the most effective control strategies will be identified and refined.

Stationary Sources Joint Forum

The focus of the SSJF is on developing a stationary source control program to help meet the reasonable progress and BART requirements of the Clean Air Act and Regional Haze Rule. The WRAP approach focuses on market-based alternatives to a plant-by-plant approach, with a particular emphasis on SO₂ and NO_x. This work plan assumes that source-by-source BART approaches will be undertaken by those jurisdictions which choose to implement BART under Section 308(e)(1) of the Regional Haze Rule.

The SSJF will conduct the analyses necessary to support market-based alternatives, such as identifying BART-eligible sources and demonstrating that any alternatives demonstrate greater reasonable progress than BART per Section 308(e)(2). The SSJF will also help coordinate any plant-by-plant BART analyses the states or tribes may choose to pursue.

Other activities by the SSJF will include tracking EPA’s BART rules and proposed guidelines. The SSJF will also work with the 309 Coordinating Committee to conduct any additional analyses that may be necessary to allow states and tribes to resubmit the SO₂ milestone and backstop emissions trading program following the court’s decision in *CEED v. EPA*.

Finally, NO_x and PM emissions must be addressed in such a way as to satisfy the SIP revision requirements under Section 309 of the Regional Haze Rule, as well as the Section 308 BART requirements for all states.

Work will include emissions inventory analysis, improvements, and future year projections; examination of control technology capabilities; maintenance of the list of BART-eligible sources in the WRAP region; and technical demonstrations that alternatives developed for BART provide for greater reasonable progress than BART.

There are several uncertainties that must be factored into this work. These include the final federal rules for Best Available Retrofit Technology (BART) which are scheduled to come out June (308(e)(1)) and November (308(e)(2)) 2005, and the extent to which WRAP states and tribes choose to implement source-specific BART rather than an alternative emissions trading program. As a result, there is a need to maintain flexibility in program design and to assess new information as it becomes available, including information from ongoing WRAP technical studies which will provide more information on the contribution of various sources to regional haze in the West. A single contractor or team of contractors will be sought for consistency over the course of the project, as developing a point and area source program will be an iterative process and may require revisiting analyses as assumptions change or new data become available.

The forum will also conduct activities needed to address sources and/or pollutants which are not included in the alternative programs.

In summary, to the extent practical, and as requested by WRAP members, the forum will coordinate the implementation of BART and address trading program design issues, such as 2018 and interim milestones; geographic, new source, and tribal considerations; monitoring and reporting requirements; enforcement provisions; economic impact assessments; and a general method for allowance allocation.

Fire Emissions Joint Forum

The FEJF projects identified in the existing 2005 WRAP Workplan, and the proposed FEJF projects for the 2006 WRAP Workplan, fall into two main categories:

- 1) The first grouping includes Planning projects to directly support the development of policy and technical tools for SIP/TIP development under §308.
- 2) The second grouping includes Implementation projects to directly support the existing fire policies and programs applicable to the implementation needs for §309 and §308.

The allocation of funding for the ongoing and planned 2005 and proposed 2006 FEJF projects is presented below at the end of the FEJF workplan. In addition to reprogramming funds allocated to FEJF in the 2005 WRAP Workplan, additional 2006 Workplan funding in the amount of \$115,000 is identified.

PLANNING

FF“C”: 2002 Inventory of Wildfire and Prescribed Fire: Phase I & Phase II

This project was funded and started in 2003 and will continue into early 2005. The 2002 base year inventories will be prepared for the contiguous WRAP region for wildfire, prescribed fire, and wildland fire use on wildland and rangeland. Agricultural burning is also included. Phase I developed an initial emission inventory to allow the RMC to initialize the 2002 modeling efforts. Phase II involves further refinement of the Phase I inventory with greater QA/QC and state/tribal review of the fire activity estimates. Data collection to support estimates of private rangeland burning and augmentation of agricultural burning will occur in Phase II. The 2002 emission inventory will include “anthropogenic” / “natural” apportionment to support the Attribution of Haze reports. These projects directly support the modeling for the §308 SIPs/TIPs.

At the request of WRAP states, statewide CERR Reports for US EPA will be developed for the Phase II inventory for all fire sources. This will allow WRAP states to submit to US EPA reports, which will partially fulfill the states’ emissions inventory reporting requirements.

The task of generating QC wildfire and prescribed fire notebooks specifically for Federal Land Managers was not included in the original Phase II scope of work. This task was requested by the FEJF in the fall of 2004. This portion of the project was funded by reprogramming 2005 funding.

FF6/3: Phase III and Phase IV Inventories & Assessment of Apportionment Methods

This project was funded in 2004 and will be started in early 2005. Phase III is for the Baseline Planning Apportionment and create a 2000-2004 representative emissions inventory. Phase IV is for the 2018 Planning Apportionment and will be a 2018 representative inventory. The 2018 inventory may include a range of potential control scenarios and possible ranges of emissions to reflect the high degree of uncertainty in this type of forecast. The inventories will be prepared for the WRAP region for wildfire, prescribed fire, and wildland fire use on wildland and rangeland as well as agricultural burning. This effort also includes development of technical approaches to apportion the impact of fire emissions between “natural” and “anthropogenic” source categories. These projects directly support the modeling for the §308 SIPs/TIPs.

This second portion of the project was funded by reprogramming 2005 funding and will be started after completion of the Phase III and Phase IV inventories. The additional assessment of apportionment methods is necessary to assess the impact of the various fire emissions inventories and apportionment methods. This project directly supports the model assessment for the §308 SIPs/TIPs.

FF7: 2002 National Wildfire Emissions Inventory

This project was funded and started in 2004. The 2002 National emissions inventory for wildfire will be developed through an inter-RPO effort funded by EPA, based on a scope of work discussed amongst the RPOs. The FEJF has lead RPO responsibilities for this project. These projects directly support the modeling for the §308 SIPs/TIPs.

The 2002 National inventory is of the most benefit to the WRAP in performing a comparative analysis to the WRAP 2002 Phase II wildfire inventory. This comparative analysis would identify the specific changes and improvements between the two wildfire inventories. The implementation of FCCS for fuel loading for the WRAP region in the National inventory is being evaluated on its technical merits by the FEJF. The National inventory paired with a comparative analysis would also be beneficial to the WRAP for the 2018 inventory to reflect sensitivity to the specific changes and improvements between the two inventories. Upon further evaluation, this task may be requested by the FEJF in early 2005 with 2005 funding. This task directly supports the modeling needs for the §308 SIPs/TIPs.

FF12: Smoke Management Technical and Policy Workshop

This project was funded in 2005 and will be started in 2005. A three-day workshop in late 2005 is planned to assess technical work to date, §309 policy and SIP implementation and refinement of policy options under §308. This effort will build on the two FEJF workshops held in 2004 to ensure that the needed technical and policy tools are in place for SIP/TIP development under §308.

IMPLEMENTATION

FF9: Regional Coordination of Smoke Management Programs

This project was funded in 2003 and was started with in-kind support in early 2005. Regional Coordination is a required element within the ESMP Policy as coordination of burning activity (ranging from passive to active) is critical to avoiding cumulative smoke impacts within and across source types in mandatory Class I areas. Avoiding cumulative smoke impacts to cultural resources is also critical. Methods for this inter-jurisdictional and regional coordination will need to be developed for wildland and agricultural prescribed fire smoke management programs, information sharing, and public notification. Proposed options will be developed, and then presented and reviewed at a facilitated conference, to be held in 2005. The task of developing proposed options may require a facilitated process. Upon further evaluation, the need for a facilitated process may be identified by the FEJF in early 2005 with reprogrammed 2005 funding. This project directly supports the implementation of the ESMP requirement in §309 as well as similar implementation issues for §308.

FF5/8: Fire Tracking System

Portions of this project were funded prior to 2002 as well as in 2004, 2005, and 2006 and will start in 2005 and continue into 2006/2007. Evaluation of existing fire emissions inventory systems to develop a Fire Tracking System as identified in the Fire Tracking System policy to calculate emissions from fire activity data. Develop user guidance to support the FTS Policy identifying a specific format, parameters, defaults, structure and methods of emission calculation for required and optional FTS elements. Develop user guidance to support the tracking of ERTs and the calculation of emissions averted, which is an optional FTS Policy element. This project

directly supports the implementation of the FTS and AEG requirements in §309 as well as similar implementation issues for §308.

In support of the AEG Policy, an annotated bibliography on ERTs was completed in the spring of 2004. Through the use of in-kind support, work was initiated in the fall of 2004 to develop technical guidance on ERTs applicable for wildland, rangeland, and agricultural burning for use in the establishment and support of AEGs. Upon completion of the technical guidance, it will become integral to the method to calculate the emission benefits of ERTs within the FTS.

FF“D”: Sensitivity Runs Phase II: Regional & Mesoscale

This project was funded in 2003 and, now that the initial Model Assessment/Sensitivity Runs are complete, will be started in 2005. Conduct an air quality source/impact analysis with two scales of modeling: regional and mesoscale. The regional-scale modeling features chemistry capacity with regional and longer temporal scales. The mesoscale modeling features complex terrain capacity with smaller geographic and temporal scales. Together, these two approaches will provide a comprehensive analysis of potential de minimus levels to assist states and tribes with maximizing efficiency for fire tracking, public notification and regional coordination. This project directly supports the implementation of the FTS and ESMP requirements in §309 as well as similar implementation issues for §308.

FF2: User Guidance and Review of Feasibility Criteria for WRAP Fire Policies

This project was funded by reprogramming 2005 funding and will be started in 2006. Feasibility criteria for the implementation of smoke management policies and programs were identified in the RHR as efficiency, economics, law, emission reduction opportunities, land management objectives and reduction of visibility impact. Furthermore, as described in the IOC transmittal letter regarding the 2001 Fire Categorization Policy, implications to cultural resources will also be examined. Feasibility criteria were adopted into the WRAP Fire Policies which in addition to the RHR criteria include safety, technical and environmental concerns. As States and Tribes assess their program options for addressing smoke from fire under §308, additional guidance will be needed as to the application of these criteria for feasibility determinations. The WRAP called for further user guidance to be developed to support the existing WRAP *Policy for Categorizing Fire Emissions*. This project directly supports the implementation of the requirements in §309 as well as similar implementation issues for §308.

Code	Project Title	Funding*	
		2005	2006
<i>Planning</i>			
FF"C"	2002 Inventory of Wildfire and Prescribed Fire: Phase I & Phase II	25,000	
FF6/3	Phase III & Phase IV Inventories & Assessment of Apportionment Methods	163,224 25,000	
FF7	2002 National Wildfire Emissions Inventory (Inter-RPO)	26,500	
FF12	Smoke Management Technical and Policy Workshop	25,000	
<i>Implementation</i>			
FF9	Regional Coordination of Smoke Management Programs	50,000	
FF5/8	Fire Tracking System	85,000	100,000**
FF"D"	Sensitivity Runs Phase II: Regional & Mesoscale (RMC)	45,000	
FF2	User Guidance and Review of Feasibility Criteria for WRAP Fire Policies	60,000	

Dust Emissions Joint Forum

DF1: Establish a Common Definition of Dust and Dust Emission Types

This project is described in previous WRAP work plans. During the initial contractor bidding process, it was determined that the scope of work and budget should be increased from \$45,000 to \$65,000. Hence, \$20,000 in additional funds is requested for this project.

DF3: Determination of Fugitive Dust PM2.5 to PM10 Ratios

This project is described in previous WRAP work plans. An additional \$30,000 is requested to ensure project completion, collection of additional samples (for a total greater than five), and/or integration of results into AP-42 and WRAP emissions and air quality modeling efforts.

DF6: Analysis of Sources and Control Options in High-Dust Areas

This project was described in previous WRAP work plans, but was not funded at the time. Hence, a revised, more detailed description is provided here. This project is a pilot study to test and demonstrate how various WRAP technical and policy products can be integrated to address the contribution of dust to regional haze at Class I areas in the WRAP region. Strengths and weaknesses of the WRAP products will be identified so that they may be improved before state and tribal implementation plans are finalized. Results will be shared with other WRAP members to inform their planning and assessment processes.

* Funding reprogrammed from FEJF allocation in 2005 Workplan (FFY04 Funding) combined with an additional \$115,000 allocated in the 2006 Workplan (FFY05 Funding).

** \$50,000 in 2006 and \$50,000 in 2007.

The NM Environment Department Air Quality Bureau (AQB) will take the lead in this effort and provide project results. The Class I area(s) selected in NM for the pilot project will have many of its 20% worst visibility days dominated by dust and will be representative of other dust-impacted Class I areas in the Southwest. The WRAP products to be used in the study, to the extent available, will include the Desert Research Institute’s analysis of ambient data; ENVIRON’s fugitive dust emissions inventory and modeling procedure for wind erosion; Countess Environmental’s Fugitive Dust Handbook; the dust definition under development; and the Attribution of Haze results. To the extent possible, the role of dust transport from Mexico will also be examined (e.g., by examining various transboundary studies and coordinating efforts with DF2, Enhanced Ambient Data Analysis).

The duration of the study is expected to be nine months. The study will include the development of a general emissions inventory of all sources associated with dust-related haze within the selected Class I Area. The emission inventory will likely be subcontracted, and the AQB would act as project manager to ensure completion of the project in a timely and costly manner. The AQB will use the emission inventory and the tools provided by the WRAP to develop a SIP-quality analysis for dust-related haze in Class I areas.

Inter-Relationship of Dust Emission Joint Forum Projects

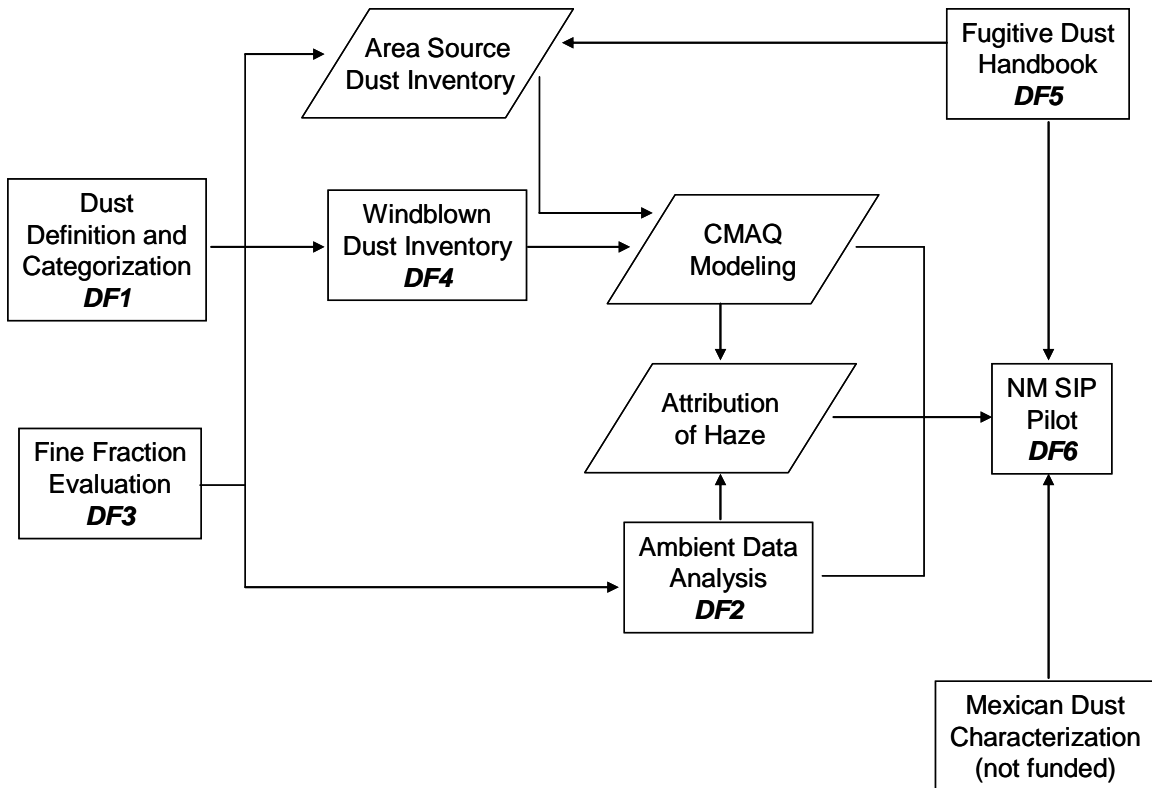

Mobile Sources Forum

The MSF work plan is a continuation of the prior work plan. No new projects or funding are being added. Below are summaries of the existing projects.

MS1: WRAP Offroad Retrofit Program

Initiated in the summer of 2004, the goal of the retrofit program is to promote voluntary emission reductions from existing offroad vehicles and equipment in the WRAP region. In 2005-06, the MSF, with contractor support, will continue to provide WRAP members and vehicle/equipment owners with written guidance, technical support, outreach services, identification of incentives and public policy options, and examples of successful efforts and reduction opportunities.

MS2: Offroad Retrofit Credits

The MSF will work with the EPA and other stakeholders to develop and implement, if appropriate, a program that uses retrofits of existing offroad sources to generate credits for compliance with new engine emission standards under the Tier IV nonroad diesel regulations. EPA has indicated an interest in working with stakeholders during 2004 – 2005 to examine the feasibility of this compliance option and implement it if appropriate. Other uses of offroad retrofit credits (e.g., for use in SIPs and TIPS) will be addressed by the Forum as needed.

MS3: Review of EPA Analyses and Proposals

The MSF will review and where appropriate recommend WRAP comments on EPA technical analyses (e.g., for small nonroad diesel engines) and regulatory proposals (e.g., for ocean-going vessels and locomotives).

Sources In and Near Class I Areas Forum

IN1: Update Near Inventory and Displays

The goal of this project is to replace the 1996 maps and data currently on the In/Near website with 2002 maps and data, and to add some additional features. The 2002 products will likely be developed by the WIGIMS / Technical Data Portal project. The Forum will cooperate in this project, and as necessary ENVIRON (the developer of the 1996 maps and data), to transfer the emission estimation procedures and display methods carefully developed for the 1996 data into the new system.

IN2: In/Near Strategies for Reasonable Progress

This project will identify which control strategies may be most effective at addressing local sources of visibility impairment. As a first step, the Forum will hire a contractor to identify all the PM₁₀ SIPs, maintenance plans, and natural events action plans in the West focused primarily

on local, primary sources of PM. Many of the existing plans rely on one or two control strategies for the bulk of emission reductions. A subset of these plans will be selected for further review. The plans selected, in total, will cover a variety of control strategy types. They will also be selected on the basis of their historical record – that is, they should provide a sufficient history of ambient data and implementation and enforcement experience to offer lessons and insights to groups involved in Class I area visibility protection (federal land managers, state and local officials, environmental groups, etc.). The result of this project will be a report summarizing the approach, success, and limitations of the most common PM₁₀ control measures; their applicability and transferability to Class I areas; and a list of contacts for more information. It will include ambient PM₁₀ data for the areas studied and summaries of interviews with officials who implemented and enforce the strategies. This project is underway and should be completed in the summer of 2005.

Economic Analysis Forum

EA2: Development of Baseline Economic Data for States and Tribes

Baseline economic and demographic data (2002 and 2018) are required to assess the potential economic impacts of proposed haze reduction strategies. A particular challenge within this task will be the continued collection and development of tribal baseline data. This portion of the effort will be closely coordinated with the Tribal Data Development Work Group (TDWG) and with the ongoing joint RPO effort to define appropriate tribal economic data requirements and templates. The overall data collection effort is being coordinated with the Emissions and Stationary Source Joint Forums (ERG contract) because many baseline emissions are based on the same types of economic and demographic data used in economic assessments. To date, baseline data has been collected for three states in the WRAP region at both the state and sub-state level as part of the recently-completed Framework Test Application. These data were collected from IMPLAN and the states themselves. EAF will participate in the overall effort to compile baseline data for the remaining WRAP states.

An RFP has been written to compile comprehensive baseline data for the remaining WRAP states. The RFP is undergoing final modifications before issuance. The final baseline data product is expected to be delivered late summer 2005. Development of the baseline economic and demographic data includes careful documentation of both the process and sources employed. In addition, that documentation will include easily applied rule sets for both modifications (if needed) and deconfliction as new information becomes available over next 2-3 years. The EAF and its contractor will provide assistance to WRAP and its respective stakeholders in generating those required baseline data and projection updates as part of the overall analyses processes as spelled out in the 2003-2008 strategic plan. In concert with the Emissions and Stationary Source Joint Forums, the EAF and its support contractor would work to ensure consistency is maintained between the baseline projections and their subsequent use by the Air Quality Modeling Forum in the conduct of its model runs of the alternative broad strategy formulations.

The TDDWG, in concert with the joint-RPO sponsored contractor are working toward a standard data “template” which is designed to formally and effectively develop the needed demographic and economic data and data sets required to support consistent economic impact and tradeoff

analysis by all. The tribal baseline work will implement that template as it works toward a complete picture of tribal conditions, and forecasts, in the WRAP region. The EAF will delay development and collection of tribal baseline data until summer 2005, when the template is to be completed.

EA3: Enhancement of Cost and Benefit Unit Values Used in WRAP Economic Analysis

The net benefit calculated for any haze reduction strategy will depend heavily on both the unit cost values (e.g., \$/ton pollutant reduced) and the unit benefit values (e.g., \$/deciview improvement and \$/statistical life saved). These values are available from only a limited number of studies. The EAF will actively seek partners to complete the effort of improving existing air quality unit cost and benefit values. It will also tack ongoing efforts, such as the National Park Service's effort to improve benefit values for visibility improvements in national parks. As unit values are improved for costs and benefits, care will be taken as to whether and how the data may be tailored to suit western visibility assessment purposes.

EA4: Screening Tool

The screening tool will be based on the WRAP Economic Analysis Framework but allow more routine, rapid, and cost-effective applications for assessing and ranking a variety and number of individual possible control measures. The WRAP Framework, in turn, would be used more occasionally to assess "packages" of control strategies that have either been well defined and/or are nearing serious consideration by WRAP stakeholders.

Before proceeding with development of the screening tool, the EAF will explore opportunities to collaborate with other RPOs and with EPA, which has already developed many components of a screening tool and integrated them into a program called ASAP. Depending on the status and plans of ASAP, it is possible that no new tool would be needed, but rather a tailoring of existing tool(s).

EA5: Coordination and Outreach

This is an ongoing and inherent task of the Forum. As noted above, the Emissions Forum and Economic Analysis Forum will co-develop and share a common set of economic and demographic baseline data. In addition, because economic analysis is dependent upon results from air quality modeling, the EAF will work closely with the Air Quality Modeling Forum. A critical area of coordination will be with tribal issues (e.g., baseline data, distributional impacts, and alternative cost/benefit unit values). Finally, outreach to other WRAP Forums and stakeholders is important to ensure proper use and understanding of economic principles and analytical results, especially since formal, comprehensive economic analysis is not typically a part of state, local, and tribal air quality analysis efforts. To improve coordination and outreach, the EAF will take advantage of WRAP-wide meetings to host periodic workshops on the application of the tools and interpretation of results of the Forum's analyses framework and supporting data sets.

EA6: Economic Assessment Capability

The EAF and its supporting contractor(s) will provide WRAP and its stakeholders with some level of on-going economic assessment capability. This may include consultation, guidance on the use of various economic data and models, and economic analysis.

Air Quality Modeling Forum

The Air Quality Modeling Forum has two major areas of activity planned for April 2005 through September 2006. The Regional Modeling Center will continue operation, to apply the tools and improvements developed in 2003-04, using the same team of contractors. A list of tasks is provided below, with a final RMC work plan completed, as described below and in a larger separate document, for 2005-06. The final RMC work plan is in the process of being amended into the existing RMC contract. The second major area of activity is to review meteorological modeling results for Class I areas in Alaska, and perform necessary and useful Alaska air quality modeling.

MF1: Regional Modeling Center

The Modeling Forum plans to continue operation of the Regional Modeling Center (RMC) with the same team of contractors as their single major project, including modeling of Alaska regional haze. The RMC will continue to provide documentation of their ongoing analysis work (including support of the Attribution of Haze Workgroup and Fire Emissions Joint Forum sensitivity analyses), protocols and technical support documents for the various analyses and work products, and disseminating this information through monthly Modeling Forum conference calls, the RMC E-Mail listserv, and periodic meetings.

The proposed 2005-06 work plan for the RMC will primarily focus on completing emissions processing and air quality modeling evaluations of revised and final 2002 emissions and 2018 emissions projections. The RMC has prepared a specific 2005-06 cost proposal and work plan that has been reviewed and approved by the Modeling Forum, and the RMC contract is now being amended to reflect this work plan. Below is a list of RMC activities for 2005-06. These tasks continue work from earlier RMC work plans as identified in the WRAP Strategic Plan.

- Process revised 2002 emissions and 2018 emissions projections
- Update new model codes for SMOKE, MCIP, and CMAQ as needed
- Continue to update post-production displays
- Run CMAQ and CAMx models with 2002 and 2018 inputs
- Conduct source apportionment/sensitivity model runs
- QA/QC:
 - Implement version control mechanism
 - EI data file to SMOKE outputs analysis & reports
 - Model performance evaluation
- Summer 2005 - 2002 final base case modeling results report
- Fall 2005
 - 2018 final base case modeling results report, followed by:

- 2018 base case final source apportionment modeling results report
- Late 2005/mid-2006 - Three to five [3-5] 2018 control strategy sensitivity modeling results reports

MF2: Alaska Region Modeling

This portion of the RMC work is aimed at providing a credible evaluation of the potential contributions to regional haze in the Class I areas of Alaska that are more likely to be affected by in-state emissions, namely Tuxedni and Denali. During 2004, the RMC completed two tasks: 1) Develop appropriate methods for running MM5 over central Alaska, including Cook Inlet, the Alaska Range, to north of Fairbanks, and 2) Run MM5 for this region for several time periods representing different seasonal and meteorological conditions and evaluate the meteorological model results. During Spring 2005, RMC staff will present the results of their work to date at a technical meeting in Alaska. Pending more specific direction after that meeting, the 2005 Alaska modeling tasks will focus on:

- Assuming the MM5 model test period runs are credible, run the MM5 model for all of 2002.
- Then run a LaGrangian model, such as CALPUFF, for the largest point sources in the region (up to about 10, addressing BART) - provide a modeling results report.
- Run the LaGrangian model [chosen previously] to evaluate the potential for impacts from the urban areas of Anchorage and Fairbanks - provide a modeling results report.

Summary of RMC Work Plan for 2005-06

As part of the 2003 work plan, the RMC completed §309 modeling for regional haze plans that were due December 2003 and began work on tasks associated with §308 requirements. Efforts in 2003 and 2004 included developing new emissions and meteorology data sets for calendar year 2002 to be used in regional haze modeling to support §308 SIPs and TIPs; implementing improvements to existing modeling tools; and developing and testing new analysis tools. Major activities in the 2004 work plan included development of emissions data for use in the 2002 modeling, meteorology modeling on both the 36-km and nested 12-km grid, testing and QA of preliminary emissions data for calendar year 2002, development and evaluation of modeling tools for the Alaska region, and source apportionment modeling using the 2002 datasets.

The following table lists high priority tasks for the 2005-06 work plan, most of which are continuation of tasks begun either in 2003 or 2004 modeling effort. More detailed descriptions of these 2005 tasks are provided in Section 3 of the RMC work plan (separate document). The RMC will consist of the same team of contractors with the University of California Riverside (UCR) as the prime contractor, and ENVIRON Corporation and the University of North Carolina (UNC) as subcontractors.

Deliverables for the 2005-06 RMC work plan.

Task	Deliverables	Date	Budget
<p>Task 1.1 Project Administration Ongoing tasks include conference calls and meeting, presentations, and project coordination.</p>	<p>1. Progress Reports 2. Monthly Project Management Calls 3. Monthly Modeling Forum Calls 4. Present Interim Results at WRAP Meetings (pending schedule of forum meetings)</p>	<p>Monthly Monthly Monthly As needed</p>	\$99,065
<p>Task 1.2 Major Reports \$7500 Jeanne Eichinger \$7500 JE \$7500 JE \$12,000 JE</p>	<p>1. Final report 2004 2. 2002 model performance (see Task 4) - Draft Report on 2002 Modeling - Final Report on 2002 Modeling 3. 2018 base case modeling (see Task 4) - Draft Report on 2018 base - Final Report on 2018 base 4. RMC 2005-06 Project Final Report (includes as appendices reports on each 2018 control scenario – for SIPs/TIPs.)</p>	<p>4/05 8/05 10/05 10/05 12/05 through 8/06</p>	\$110,459
<p>Task 1.3 Computer Systems Administration</p>	<p>1. Maintain Website and Listservs 2. Computer systems maintenance</p>	<p>Ongoing Ongoing</p>	\$78,562
<p>Task 2. Emissions Modeling and Processing A. Final 2002 Version A emissions and QA reports B. SMOKE - new Mexico EI, new Canada EI C. "improved" WRAP region 2002 EIs from EDMS D. Typical Fire 2000-04 E. Initial WRAP region 2018 base case EI F. 2018 control strategy scenarios from EDMS: 5 cases, one of which is the BART EI from Task 6 G. 2018 Updates from other RPOs</p>	<p>36-km emissions (Final02a) 12-km emissions (Final02a_12) Final 2002 version B emissions (Final02b) Final 2002 version C Base 2018 emissions</p>	<p>6/05 6/05 6/05 9/05 starting 9/05 ongoing</p>	\$168,079
<p>Task 3. Meteorological modeling: No new work planned</p>			\$0

Task	Deliverables	Date	Budget
Task 4. Air Quality Modeling			\$172,677
A. CAMx Evaluation	Pre02d 36km simulation w/ MPE evaluation Pre02d 12km simulation w/ MPE	4/30/05 5/30/05	
B. CAMx and/or CMAQ: MX and Canada Emissions Updates	2002 36km simulations w/MPE 12-km MPE simulation w/ MPE	6/05 7/05	
C. CAMx and/or CMAQ: 2002 Improved Emissions from EDMS	Final 2002 36km simulations w/MPE Final 12km MPE w/MPE (optional)	6/05 8/05	
D. Report on 2002 Modeling including: 1) Modeling report – emissions, met, procedures 2) individual model diagnostic analysis, 3) complete performance analysis metrics for both models 4) protocol to identify primary vs. corroborative and reconcile/compare/analyze 2 models’ results 5) RRF/visibility projection protocol (by species) finalized	Draft protocol and ppt presentation Final protocol and ppt	10/05	
E. CAMx and/or CMAQ: 2018 Base Case using EDMS emissions	Final 2018 base case 36-km simulations 12km simulations (optional)	10/05 12/05	
Report on 2018 Base Case Modeling including: 1) individual models’ results, 2) apply protocol to identify primary vs. corroborative and reconcile/compare/analyze 2 models’ results 3) apply RRF/visibility projection protocol	Draft results report and ppt Final results report and ppt ppt for each scenario Final results in RMC 2005-06 report and ppt	12/05 – 7/06 By 8/06	
AQM simulations at either 36-km or 12-km resolution for each of the five (5) 2018 control emissions scenarios listed in Task 2.			

Task	Deliverables	Date	Budget
Task 5. Wind Blown Dust Model	Diagnostic evaluation of CMAQ results Additional work per DEJF: 1. Modify transport factors? 2. Modify Coarse & Fine emissions factors 3. Natural versus Anthropogenic emissions 4. Emissions Sensitivity Cases	4/05 through 7/05 through 7/05 through 7/05 through 8/05	\$26,033
Task 6. BART Modeling Project A. Determine visibility impact of BART-eligible sources in the WRAP region. B. Determine the improvement from application of BART to sources based on criteria from the EPA BART Rule as specified by the Stationary Sources Joint Forum. C. From #2, prepare up to 3 WRAP regional BART emissions scenarios for 2018 control strategy scenario modeling analysis using CMAQ and/or CAMx models.	Modeling protocol for A and B, following. Use CalPuff model as specified in EPA April 2005 rule – Report tabulating results Use CalPuff model as specified in EPA rule, for individual sources meeting criteria as provided by SSJF – Report tabulating results BART regional emissions scenarios following criteria from SSJF – Summary report.	5/05 Start 6/05 Start 9/05 12/05	\$105,239
Task 7. Fire Sensitivity Phase 2 – Regional and Mesoscale A. small fires and clusters in and near Class I areas B. Large fire vertical distribution – test EPA SMOKE tool 1) simple sensitivity run, 2) develop new plume rise model for fires (optional)	EI; AQM results, ppt file, text for white paper New EI for wild fire, AQM results, ppt file	9/05 9/05	\$47,224
Task 8. Completion of Alaska Modeling A. Present MM5 and AQ work to date – April 26-27, 2005 B. Continue regional modeling work for Alaska (optional)	Initial Results, recommendations Final Report TBD	4/05 5/05	no 2005-06 \$, complete with 2004 \$

Task	Deliverables	Date	Budget
<p>Task 9. Natural Haze Emissions Inventory: Motivation – identify model “floor” for clean conditions (NOT attempting to simulate actual natural conditions) Emissions modes or data are currently available for: Natural wild fires Natural dust emissions GEOS-CHEM boundary conditions Emissions mode available but needs to be run: Sea Salt Emissions Models still needed for these categories: Lightning NOx Geogenic seeps and volcanoes</p>	<p>Emissions Inventory CMAQ Simulation</p>	<p>After natural dust EI is available</p>	<p>\$12,265</p>
<p>Task 10. Source Apportionment: <i>Final report on 2004 modeling is in progress.</i> Additional model simulations using CAMx/PSAT as needed pending completion of AQM modeling in Task 4</p>	<p>Source Apportionment report</p>	<p>4/05 9/05</p>	<p>\$47,376</p>
<p>Task 11. Technology Transfer and Data Distribution: Training classes available from CMAS. Free support available through CMAS. Additional support can be provided from RMC team if requested.</p>	<p>Met, Emissions, and AQM results available to be sent by FedEx on portable disks Document describing standard configuration for computer systems and model setup.</p>	<p>As needed 6/05</p>	<p>\$0 roll over of funds from 2004</p>
<p>Task 12. Computer Hardware: New equipment - 30k for 8 TB Xserve RAID5 disk storage, includes support contract, 5k replacement parts for compute nodes Additional equipment costs for 12-km modeling</p>	<p>12km needs - TBD</p>		<p>\$35,000</p>

Emissions Forum

The Emissions Forum is planning to continue a major project and several specific supplementary projects during 2006. The Emissions Data Management System (EDMS) is the major project of the Forum, as an ongoing data center and repository. During 2006, EDMS operation and maintenance of EDMS will continue. Several EDMS enhancements are planned. The enhancements include some of the items that were postponed from earlier budget plans, and referred to as Phase II enhancements. Others were identified during Beta testing and are defined in the EDMS Acceptance Plan.

In addition to EDMS work, some states have begun to identify needs for more emissions inventory data to develop §309 SIP control strategies. The work plan includes an effort to poll states for these needs and to assist states in meeting some of these data requests.

Budget Summary for 2006

EF1: EDMS operation and maintenance.....	\$180,000
EF2: Phase II EDMS enhancements.....	\$128,000
EF3: Emissions support for control strategy development.....	\$75,000
<hr/>	
Total funding requirements for 2006.....	\$383,000

Emissions Forum Projects

EF1: EDMS Hosting / Operation

This project supports ongoing operation, maintenance, standard software and hardware upgrades, and computer system hosting for the EDMS during 2006. The amount of \$60,000 is set aside for E.H. Pechan, for hosting and hardware support by their computer systems subcontractor, Carolina Environmental Programs. In addition, \$120,000 is proposed to continue Pechan's operation and administration of the EDMS, including data analysis products, data provider/user assistance, and general oversight. This will be accomplished by Pechan's database administrator and a data analyst.

EF2: Phase II EDMS Development Efforts

1. Acceptance of XML Data Submittals - Estimated Cost: \$20,000

Description/Deliverable: This task entails adding parsing routines to accept and report data in the XML format.

Benefits: Would allow acceptance of data in XML format. New Mexico needs this format for future data submissions.

Strategic Plan Timing Issues: XML format needed in time for next data submission for New Mexico, which would be next year's SO2 tracking data.

2. Other Enhancement Needs Identified During Beta Testing - GIS Display improvements and improvements from Acceptance Plan: \$38,400

There are currently 20 issues marked as potential enhancements that were identified during the EDMS Beta testing effort. These issues were identified in the EDMS Acceptance Plan and are shown below. Time and cost estimates should be considered 'ballpark' and not heavily researched. The enhancements that appear below are thought to be outside of the original design.

Enhance Facility GIS Display - Reduce the overall number of facilities manipulated by the GIS interface so that performance is not taxed. The facilities to be presented might be limited by emissions volume, such as:

- Facilities with emissions greater than X for any pollutant - value x to be fixed rather than user-prescribed. It is estimated that this functionality can be added for 20 hours programming time plus 4 hours DBA time (\$1,872).
- Top X% facilities in WRAP region for specific pollutant. Value x to be fixed rather than user-prescribed; pollutant to be selected by user from pick list. It is estimated that this functionality can be added for 32 hours programming time plus 8 hours DBA time (~\$2,392).
- Filter Facilities based on SIC Code. It is estimated that this functionality can be added for 32 hours programming time plus 8 hours DBA time (~\$2,392).
- Filter Facilities based on tiered SCC code, similarly to standard reports functionality. It is estimated that this functionality can be added for 40 hours programming time plus 10 hours DBA time (~\$2,990).
- Total for GIS Display enhancement is \$9,646.

Enhancements from the Acceptance Plan

Description	Time Estimate (hours)	Cost Estimate (dollars)
Add a 'Back' button on submitted data summary screen to facilitate submission of several files.	8 programmer; 1 DBA	\$678
Tabular report suggestions: Add user ability to change the filter parameters in the Tabular data view and not have to go back to the graphical chart view; add user ability to select more than one county (and less than all counties) in a state to view on the graphs and tables; add user ability to view state totals without viewing county totals also.	16 programmer; 8 DBA	\$2,064
Efficiency on Extraction Transfer Loading (ETL) from Transaction Database (TXN) to Staging Database (STG) - driver script needs review to improve efficiency, currently Record Add/Record Delete and Delete steps commented out in production since they are not needed.	8 programmer; 8 DBA	\$1,504
Change return of ETL and diagnose procedure from number to error message. Use production master diagnose as guide.	16 programmer; 2 DBA	\$1,356
Diagnose flags QC check not scaling well for very large files, review to improve efficiency.	8 programmer; 8 DBA	\$1,504
state/tribal names - make sure the differentiating part is early in the string expression so that it will be useful in pulldowns	4 programmer; 1 DBA	\$398
Modify the function that creates Excel and Access export files to produce null valued fields rather than zero-valued fields where no data is reported.	20 programmer; 8 DBA	\$2,344
GIS – provide bigger border for states so that states can be differentiated from counties when zoomed in.	8 programmer; 1 DBA	\$678
GIS – Add tool tips on GIS buttons	8 programmer; 1 DBA	\$678

Description	Time Estimate (hours)	Cost Estimate (dollars)
Disaggregate information in NAME column on standard reports, currently contains name, address, other values in one field.	8 programmer; 2 DBA	\$796
Provide checks that data owner has submitted data for only their own jurisdiction	32 programmer; 16 DBA	\$4,128
Write jpeg files generated on the fly to temporary storage so that they can be exported normally, allowing users to open directly rather than requiring them to save to disk first.	8 programmer; 2 DBA	\$796
Change spacing near all colons (:)	6 programmer; 1 DBA	\$538
SVG may not work with IE 5.0 on a MAC	32 programmer; 16 DBA	\$4,128
Section 508 compliance – graphics portrayed with patterns instead of colors, all-text versioning.	If pursued, more definition required.	
Switched to Tabular view without hitting "go"	20 programmer; 4 DBA	\$1,872
GIS – combine select and update into one button click	16 programmer; 4 DBA	\$1,592
Timeout message needed	8 programmer; 2 DBA	\$796
"Export /PDF" function for bar charts produces charts wit...	8 programmer; 4 DBA	\$1,032
GIS - Import/Export/Edit list of selected features	20 programmer; 4 DBA	\$1,872

3. Capability to Geo-Code Certain Area Source Categories: Estimated Cost \$20,000

Description/Deliverable: Entails minor modifications to database and supplementary data submittal formats, as well as data uptake system and GIS display routines.

Benefits: Would allow for certain area sources to be geo-coded in the database (e.g. landfills, minor point sources).

Strategic Plan Timing Issues: Could provide useful geo-information for attribution and control analyses, etc. scheduled for 2005-2006.

4. Low Graphics Version of EDMS: Estimated Cost \$30,000

Description/Deliverable: Provide users without high-speed Internet connections an attractive and intuitive interface to view, query, and report EDMS data

Benefits: Would allow users that do not have high speed to access data more easily thus improving access/communication of data to certain stake holders. This may be of more

benefit to tribal users that may not have high speed computer access as well as other stakeholders and public users.

Strategic Plan Timing Issues: Does not help to meet any strategic planning milestone.

5. Method for Biogenic/Dust Feedback Loop: Estimated Cost \$20,000

Description/Deliverable: This task entails devising a method to return required revisions to modeled outputs concerning biogenic and dust emissions back to the relevant model inputs. This outcome of this task is more likely to be a statement of protocol rather than specific modifications to functionality of EDMS or other systems.

Benefits: If states/tribes provide biogenic or dust emissions, this method would be a first step at getting those emissions/activities back to the RMC. At this time the RMC would not have the disaggregated information coming from EDMS to feed back into their process.

Strategic Plan Timing Issues: Does not help to meet any strategic planning milestone, would improve data flow between EDMS and RMC.

EF3: Emissions Support for Control Strategy Development

Now that the Attribution of Haze project is providing additional information that will enable states to identify emission sectors and possible control strategies, the Emissions Forum anticipates requests from forums and states for additional emissions data in areas that are key concerns for their Class I areas. The Emissions Forum intends to poll states in the first half of 2006 to determine their specific data needs, particularly for states that do not collect emissions data for some sectors. We do not anticipate that all needs can be met, but request \$75,000 in 2006 to provide assistance on priority tasks.

2007 Emission Forum Work Plan

EF1: EDMS Hosting / Operation

EDMS operation and maintenance will continue at an estimated cost of \$180,000. Our experience with EDMS during 2005 will allow us to better estimate annual cost for future years.

Tribal Data Development Work Group

The Tribal Data Development Work Group is planning to continue a major project and several specific supplementary projects during 2006. The Emissions Data Management System (EDMS) is the major project of the Forum, as an ongoing data center and repository. During 2006, EDMS operation and maintenance of EDMS will continue. Several EDMS enhancements are planned. The enhancements include some of the items that were postponed from earlier budget plans, and referred to as Phase II enhancements. Others were identified during Beta testing and are defined in the EDMS Acceptance Plan.

In addition to EDMS work, some states have begun to identify needs for more emissions inventory data to develop §309 SIP control strategies. The work plan includes an effort to poll states for these needs and to assist states in meeting some of these data requests.

TDDWG Budget Summary for 2006

TW1: Analyses to support Tribal partnerships in developing SIPs	\$100,000
TW2: Tribal data into the 308 SIP/TIP Technical Support Document	\$ 50,000
TW3: Continued Support of the Tribal Emissions Inventory Software Solution	\$ 50,000
<hr/>	
Total 2006 TDDWG Request.....	\$ 200,000

TW 1: Specific analysis to facilitate effective Tribal partnership in developing SIPs:
Estimated Costs: \$100K.

Goal: Effective Tribal participation in the SIP decision-making process that the States will undergo in for the first round of 308 SIPs due in 2006/2007.

Objective: To provide specific technical analyses for each of the developing SIPs which will give, in a timely manner, the information that Tribes need to participate effectively in the SIP processes. These analyses would be done by a contractor(s) who has both Tribal policy and technical expertise and knows how state actions can affect Tribes.

Deliverables: Analytical documents that specifically address each developing SIP and how they may impact Tribes. These documents may include, but are not limited to, the following types of analyses:

- Analysis of current or draft Federal, state and local smoke management programs and current tribal plans and how they may affect Tribes in the WRAP region. As an example: an analysis of the current actions in Region 10 to create a FIP to address smoke management on or near Tribal lands.
- Analysis of regional haze point source control programs and how they may affect Tribes.

TW 2: Incorporation of Tribal data into the 308 SIP/TIP Technical Support Document:
Estimated Cost \$50,000

Goal: As Tribes develop their TIPs and identify specific sources that need to be factored into the regional efforts to reduce haze, it will be important to amend the TSD to account for these sources and to provide states with guidance on how to best incorporate Tribal data into their SIPs. This task would provide for a contractor to track the TSD as it is developing and to ensure that Tribal data is accurately incorporated into it.

Objective: SIPs that accurately reflect Tribal emissions and monitoring data.

Deliverable: A report to the TDDWG regarding incorporation and coordination of Tribal data into the TSD.

TW3: Continued Support of the Tribal Emissions Inventory Software Solution (TEISS):
Estimated Cost \$50,000

- 2 Trainings. There is an ongoing need to continue TEISS training for Tribal air staff due to employee turnover and the fact that there are developing Tribal air programs that will be ready to conduct EIs in the future - estimated cost: \$40,000
- Annual update of TEISS license - \$10,000

Ambient Monitoring and Reporting Forum

The Causes of Haze Study is a complex, multi-year project, with results posted to a web site as available. The tasks from the original proposal are outlined below. In addition to these specific tasks, considerable effort has been expended setting up the web site. A request of \$225,000 for 2006 work detailed below, to complete the original scope of the project, and is accompanied by a \$100,000 request to maintain and update the website during 2007.

1	Emissions Mapping & Description
2	Monitoring Site Settings
3	Meteorological Setting
4	Aerosol Description
5	Back Trajectory Analysis
6	Conceptual Model
7	Reporting
8	Episode Analysis
9	Detailed Meteorological Analysis
10	Emissions Trends
11	Receptor Modeling

Tasks 1-5 have been completed, as described more fully in a memorandum sent to WGA on December 1, 2004. Further back trajectory analysis, however, will be conducted for 2003-04.

Task 6 (conceptual model development) has been indefinitely postponed in order to focus on the trajectory regression attribution (see Task 11 discussion).

Task 7 (reporting) is ongoing with results posted to the COHA website (www.coha.dri.edu) as completed.

Task 8 (episode analysis) has been performed for the following episodes:

- Forest fires 7/10/99, 8/2/00
- Eastern US sulfate transport to Colorado Plateau 9/3/97, September 1998
- West coast nitrate 2/16/02
- Fall stagnation 9/5/02
- High wind dust episode 4/22/01
- Wildfires and dust 8/11/01- 8/23/01
- Colorado Plateau sulfate 4/7/01

- Southern Arizona dust 10/16/01
- Asian dust 4/16/01
- Volcanic sulfate in Hawaii

Additional episode analysis is planned.

Task 9 (detailed meteorological analysis) will include an assessment of the representativeness of 2002 (the year used for air quality modeling purposes) relative to the 2000-2004 baseline conditions. Some assessment of the quality of the back trajectory data is also planned.

Task 10 (emission trends) will be amended to focus on trends in haze and its constituents, as opposed to emissions. Much of this work has already been completed.

Task 11 (receptor modeling) is being done using back trajectory endpoints and aerosol data to apportion sulfate and light extinction to geographic regions (e.g. individual states, groups of states, Canada, Mexico). This analysis will be completed in early December 2004 for all sites with at least one year of aerosol data during the 2000-2002 period.

Technical Oversight Committee (ToC)

ToC1: GIS Landuse Database Update

The overall objective of the GIS Landuse Database project is to develop updated, current year (2000-04) GIS databases for use in air quality and emission inventory development efforts. Specific uses of these data may include the following:

- air quality analysis and support of source attribution/apportionment activities;
- improvement of near-field activity data and analysis of emissions strengths;
- provide more uniform landuse and demographic data to make temporally consistent regional estimates of biogenics, ammonia, and windblown dust emissions, as well as providing a consistent baseline for area source activity data and planning; and
- development of appropriate GIS data layers for Canada and Mexico.

The Planning Team approved the \$50,000 funding at their March 2005 meeting, for this short-term project to be complete in June 2005, using existing budget resources. The data and products from this project will be put to immediate use by the RMC, for the AoH projects described below, and by planners and managers at state and tribal air agencies. As this project is already underway, this project is not shown on the “March 2005 Status Report - Pending Projects” table earlier in the workplan.

Attribution of Haze Workgroup (AoH)

In support of the activities described WRAP Strategic Plan, the TOC established an Attribution of Haze Workgroup in early 2004. This “Phase I” Attribution analysis and report for all Class I areas in the WRAP region was completed in March 2005. The next step in this process will be complementary 2005-06 analysis activities by the various Forums and Workgroups in support of the AoH “Phase II” project, anticipated to begin in mid-Summer 2005, to analyze improvements in haze between the final/revised 2002 emissions estimates available early in 2005, and the emissions estimates for the 2018 base and control strategy scenarios’ cases. No additional 2006 funds are requested.

AoH1: Attribution of Haze – Phase 2 Contractor Support

The AoH Workgroup plans to execute the Phase II AoH project described above. It is planned that the Technical Data Portal project listed next will accomplish most, if not all, of the reporting formats and capabilities needed in the Phase II project, funds are set aside to ensure that technical support and preparation work can be completed in a timely manner. If the Technical Data Portal project is moving ahead on schedule, then these funds may be redirected to that project, or not used by the AoH workgroup. If needed, similar to the Phase I AoH contractor support project, for the \$75,000 currently budgeted from the 2005 workplan, the contractor will:

- Attend AoH Workgroup meetings and distill members’ opinions and results of discussions into a schedule and methodology to accomplish the Phase II tasks;
- Possibly subcontract with independent experts for analytical work;
- Gather and format the resulting information and data from WRAP Forums, independent experts, and other related air quality analyses, all for review by the Workgroup;
- Draft a “Phase II AoH Report” for review and comment by the Workgroup; and
- Complete and publish a “Final Phase II Attribution of Haze Report”.

AoH2: Technical Data Portal Project

At the direction of the TOC during 2004, Pangaea Information Technologies prepared a series of 3 white papers comprising the WRAP Integrated Geospatial Information Management Strategy (WIGIMS) report: (http://wrapair.org/forums/toc/documents/wigims/WIGIMS_Strategy_Report-final.pdf). These papers document a progression from a needs assessment to a resource inventory and a final strategy document. The strategy document lays out a range of options and a recommended approach to create a structure for data and information management of monitoring data/analyses, emissions information, air quality modeling simulation results, and ancillary data. The concept is to allow WRAP users and interested parties to access these data through a single web-based technical data portal (TDP) using web-based Geographic Information System[s] (GIS) tools to view and analyze the data used in WRAP regional haze planning work. Implementing the WIGIMS recommendations and strategies through a WRAP TDP project will incorporate suggestions and recommendations from the Pangaea strategy document into a phased approach, resulting in a scope of work for contractor support to build and operate a technical data portal for the WRAP region.

While still under development, the scope of work for this approach to the WRAP TDP project would likely consist of three components and provide access to data that could be used for a wide variety of analyses. At a minimum, this RFP would need to list:

1. Examples of the specific analytical products and “canned” regional technical documentation and displays needed for the §308 regional haze implementation plans (SIPs and TIPS);
2. A description of a structure(s) for a flexible data access structure for more detailed analyses needed for individual SIPs and TIPS (borrowing options from the Pangaea reports); and
3. Flexibility for ad hoc storage, and subsequent data query and analysis for interested parties, so “weight of evidence” demonstrations used in individual SIPs and TIPS can be reviewed.

The ability to combine air quality observations/analyses, modeling results, emission inventory estimates, and any ancillary GIS data makes preparing the “weight of evidence” analyses described in #2 and #3 possible. The \$167,000 currently budgeted from the 2005 workplan will be used for this project.

309 Coordinating Committee

The purpose of this committee is to coordinate the implementation of Section 309 SIPs and TIPS. This includes tracking emissions for the backstop SO₂ trading program and addressing issues related to that program. EPA’s process of reviewing, proposing approval, taking public comment, and taking final action on the 309 SIPs submitted in 2003 has been put on hold pending resolution of issues raised in CEED v. EPA.

The committee will continue to interact with EPA to identify and address any revisions and updates to certain SIP elements and will serve as the coordination point for the 309 states as this process moves forward. Committee members include representatives from the states that submitted Section 309 SIPs and tribes interested in submitting Section 309 TIPS.

Air Managers Committee

2006 will be the third year of the current strategic plan. Practically, this is the final year to conclude the essential technical and policy work needed by states and tribes for 2007 SIP and TIPS. The Air Managers Committee role to assure and assist in completion of these projects will be essential. The state and tribal caucuses will continue their current staffing levels, including the Alaska Tribal Coordinator, to help accomplish its goals in 2006. The AMC Implementation Work Group “customers” began their work in earnest in 2004. The IWG will continue through 2006 to:

- Help guide and assess project output from the other WRAP forums and workgroups;
- Develop a roadmap or template/framework that states and tribes may use to construct their individual SIPs and TIPS;
- Compile information on supplemental benefits of regional haze control strategies, and;
- Facilitate the essential understandings between states and tribes to develop and implement their SIPs and TIPS.

AMC1: Staff Support for the State and Tribal Caucuses

The State and Tribal Caucuses each have a caucus coordinator as staff to assist the tribal and state air directors with continual tracking and reporting of WRAP activities, issue identification and communication among the WRAP partners, recruitment of WRAP participants from states and tribes, and facilitation of issue resolution. The State Caucus Coordinator position is filled through a services contract between WGA and WESTAR, and is listed as an AMC budget item. The Tribal Caucus Coordinator and the Alaska Tribal Outreach Coordinator positions are funded directly through NTEC, are not included in the AMC budget table below, but they are included as part of the NTEC budget for WRAP support.

AMC3: Summary of Supplemental Benefits of Regional Haze Controls

Although virtually all of the work within the WRAP is directed toward supporting states and tribes in meeting requirements of the Regional Haze Rule, it is apparent that there are supplemental benefits to reducing air pollutants associated with haze. These benefits are related to health, ecosystem, cultural, agricultural and other factors. While haze is the primary focus of any control measures considered under the Regional Haze Rule, it is helpful when considering potential emission control measures, to also evaluate supplemental benefits where possible. Much of this information can be gained from the results of on-going WRAP activities and other outside sources, but it is scattered and not organized in a useable form for consideration. Distilling such information and putting it into a communication package for managers, stakeholders and the public will assist states and tribes in describing the full value of emission control measures considered to meet regional haze requirements.

The purpose of this project is to identify and describe these supplemental benefits and how they would follow from regional haze controls in a way the public can understand. The final summary material will be useful to WRAP participants for communicating the full merits of their regional haze control programs, and identifying ways in which existing WRAP datasets, models, and monitoring networks may be optimized to provide more quantitative estimates of supplemental benefits.

Although this project will be carried by AMC, it is expected that the Economic Analysis Forum will actively participate in it. The work of identifying and compiling the available information will require the assistance of outside expertise with knowledge of where the data is, how it can be used. The final work product will consist of written and visual material in one or more formats suitable for workshop settings. This may include printed and PowerPoint® presentations.

AMC4: Development of TSD “Section” Addressing Visibility Impact to Traditional Tribal Lifeways

Although there are several forums, (i.e. CoHA and FEJF,) addressing Tribal visibility impacts, this data needs to be compiled into a technical support document (TSD) component that would be useful in the development of SIPs/TIPs. This task would give a comprehensive view of the relationship between regional haze and its effects on Tribal lands and traditional lifeways. The document will describe why tribes need to be concerned with regional haze and how their involvement in the WRAP serves to reduce the haze that may interfere with their traditional practices.

This document will serve as an educational tool for WRAP participants (and members of other regional planning organizations) that regularly work with and/or live near tribal lands. It is anticipated that the documents will be professionally developed into a document to be included in the 308 TSD.

AMC5: Implementation Work Group (IWG)

The IWG got up and running in 2004, and will continue its work in two principle areas through 2006: First, IWG is on track to develop one or more “templates,” or “roadmaps,” to assist states and tribes in writing their 308 and 309(g) plans. In addition the IWG will maintain ongoing communication with the other forums and oversight committees as needed, prompting timely information from states and tribes, and in turn providing feedback to the forums to ensure they are focused on the critical planning questions. WESTAR provides direct staff assistance under a services contract with WGA. The State of New Mexico provides additional part-time contract staff to address the specific planning needs of tribes.

AMC6: Workshops on Effective Collaboration

In the last year, during discussions among states and among tribes, reference has been made several times, along the lines, “The Tribes won’t talk to us.” or “State (agency) is making assumptions we don’t agree with.” Although there are examples of collaboration among states and tribes on specific projects, states in general have more mature air programs than most tribes and they must meet certain deadlines. Tribes are not subject to these deadlines. There is strong opinion among some of the tribes that they are included in WRAP work when it is convenient or in name only. Some states have little to no working relationship with tribes in their respective states. A number of tribes are reluctant to release tribal information because they are distrustful of state and federal regulators.

This task would begin to strengthen working relationships between states and tribes that is essential in order to fulfill the requirements of the regional haze planning process and the Regional Haze Rule. EPA’s Regional Haze Rule explicitly addresses state-tribal relationships and directs them to work collaboratively with each other and in “partnership with other interested stakeholders,” but provides little guidance in this regard. The goal of these workshops is to facilitate improvements in working relationships within WRAP and among individual states, tribes and federal agencies, by enhancing the understandings of leadership and staffs of these

entities about how each of them functions within their organizations, their various operational protocols and traditions.

In general, the form of this project is a series of sub-regional workshops at selected locations within the WRAP region to instruct state and tribal WRAP partners in tribal/state protocols. Tribal and state leaders would address in turn their procedures and expectations of consultation, their governing structures, environmental priorities and their efforts toward collaboration. The focus would include identification of barriers to collaboration and ways to overcome them. Interested stakeholders would be invited to give insight into their organizational structures and collaborative efforts.

AMC 2006 Budget Table

Project Code	Project Title	Projects Pending	2006 Request
AMC1	State Caucus Staff Support (WESTAR)		120,000
AMC3	Supplemental benefits of Haze-related control measures	15,000 (-30k) ¹	
AMC4	TSD Section on Haze and Traditional Tribal Lifeways	10,000 (-25k) ¹	
AMC5	308 Implementation Work Group Support (WESTAR, New Mexico)	20,000 ²	38,000
AMC6	Workshops on Effective Collaboration	35,000	
	Contractor Assistance	145,531 ³	
Totals		225,531	158,000

¹ These figures represent decreases from 2005.

² This figure may have been expended for staff support to develop 309 TIP template.

³ This figure includes -\$11,049 from 2005 for the tribal emission inventory part of the Stationary Sources Joint Forum EI project approved by AMC in February 2005.

Communications Committee

CC1: Web Site Maintenance

Primary communications tool for the WRAP. Consider additional funding for transition to new Operations/Maintenance Contract for improved performance.

CC2: Continue and Expand Publications

This work is intended for both internal and external audiences and includes the following:

- Collect inputs, draft and publish The WRAP Sheet on the Web site;
- Print, mail, and/or fax hard copies of The WRAP Sheet to selected recipients; and
- Produce brochures, fact sheets, and other handout materials for conferences, exhibits, and public meetings.

CC3: Update Presentation Materials to Tell the WRAP Story:

- Tailor the WRAP 301A, 401 and Tribal version presentations to meet needs of various forums/committees; and
- Convert presentations to various video formats (CD, VHS, 35mm, etc.) and make copies for multiple venues.

CC4: Expand Speakers' Bureau

Assure exposure of WRAP story to state and tribal general audiences throughout the WRAP region. Tailor to individual audiences as appropriate:

- Develop and maintain data base of prospective audiences;
- Work with state and tribal air directors/forum and committee chairs and follow up on contacts to schedule presentations; and
- Coordinate presentation and support materials for all scheduled events.

CC5: Support WRAP Forums and Committees in Conducting Public Meetings

Inform and obtain public input on WRAP products and related SIP/TIP development efforts:

- Assist with arrangements for meeting venues; and
- Coordinate presentation and support materials for all scheduled events.

CC6: Other Outreach Efforts to Reach Wider Audience

Investigate partnering with other agencies/programs with shared goals – e.g., Pollution Prevention Roundtable for AP2 presentation:

- Identify potential partnerships and follow up to develop cooperative ventures; and
- Participate in joint ventures with mutual benefit.